



The Use of Nanofibers in the Clothing Industry

Roman Knížek*

Department of Textile Evaluation, Faculty of Textile Engineering, Europe

*Corresponding author: Roman Knížek, Department of Textile Evaluation, , Faculty of Textile Engineering, Europe.

Received: 📅 March 11, 2018

Published: 📅 March 18, 2018

Abstract

These days, nanofiber layers are used not only for filtration and separation purposes, but also in the clothing industry. Nanofiber membranes are highly suitable for this purpose because of their high porosity, which is 25 % higher than the porosity of common porous PTFE membranes, and which provides much better water vapour permeability than other membranes available on the market.

Keywords: Nanofiber Membrane; Nanofiber; Outdoor

Membrane for Use in the Clothing Industry

In Figure 1 you can see how such a nanofiber membrane for clothing works. Drops of water (snow, rain) fall on the top surface material. The top material tries to stop these drops from getting under this textile. This top material is often impregnated or has some chemical finish to achieve this, but at the same time it must be able to let water vapor through. This top material with its good properties has also got its limits and that's why a nanofiber membrane is added. The different materials (woven or knitted textile and nanofiber membrane) are laminated together to form 2-layer, 2.5-layer or 3-layer laminates. The membranes are made of polymers, the most common ones being PTFE (Polytetrafluoroethylene), PES (Polyethersulfone) or PUR (Polyurethane). The membrane thickness is in the range of micrometer units [1-3].

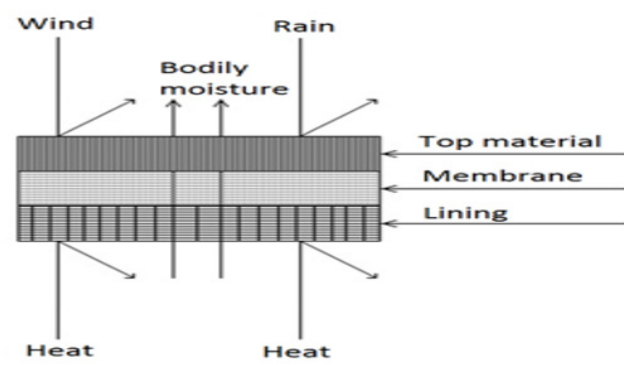

Figure 1: The membrane function diagram.

Nanofiber Membrane Development

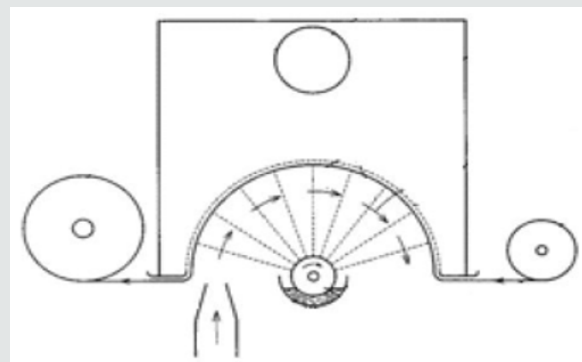

Figure 2: The Nanospider machine for the production of nanofibers by electrospinning [4].

A Nano spider machine was used to produce the nanofiber membrane (Figure 2) [4]. Polyurethane polymer was chosen because it is easy to use on a Nano spider machine, but also for its elasticity as it gives the final laminate sensibility that is very desirable in some kinds of clothing. The produced nanomembrane is made hydrophobic using Fluorocarbon type C6 monomer in low vacuum plasma to achieve a higher hydrostatic resistance. The hydrostatic resistance can be more than 20,000mm depending on the top material laminated to the membrane. After hydrophilization the nanomembrane is laminated together with other textile materials. Many long-term tests have shown that a 3-layer laminate is the only solution for nanofiber layers as these layers are very

susceptible to friction and for that reason must be well protected on both their sides by other textile materials laminated onto them. Figure 3 shows such a 3-layer laminate.

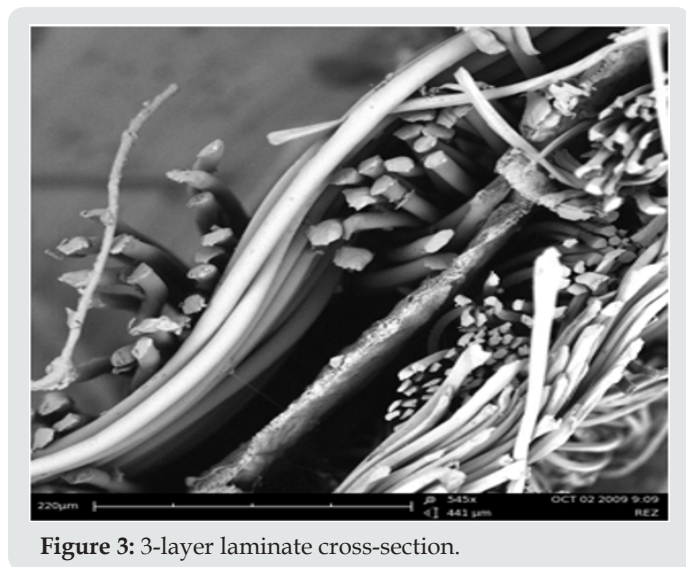

Figure 3: 3-layer laminate cross-section.

Results

Table 1 shows the results for 2-layer and 3-layer laminates with a nanofiber membrane and also a 3-layer laminate from the Gore-tex company (with the same areal weight).

Table 1: 2-layer and 3-layer laminates with a nanofiber membrane and also a 3-layer laminate from the Gore-tex company (with the same areal weight).

	2-layer laminate	3-layer laminate	3-layer laminate with PTFE membrane (Gore-tex)
Water vapour permeability [Pa. m ² /W]	1	1.6	2.5
Air permeability [l/m ² /s] at 100 Pa pressure	< 3	< 2	0
Hydrostatic resistance [mm]	6 000	> 10 000	> 10 000



This work is licensed under Creative Commons Attribution 4.0 License

To Submit Your Article Click Here: [Submit Article](#)

DOI: [10.32474/LTTFD.2019.03.000158](https://doi.org/10.32474/LTTFD.2019.03.000158)

Top layer: 100% PES, 80gsm, ripstop weave

Membrane: 100% PU, 3gsm

Lining: 100% PES, 66 gsm, weft-knit fabric

Gore-tex: Active

The results show, that the nanofiber layer laminate has a much higher water vapor permeability than the laminate with a Gore-tex membrane while at the same time both laminates have a similar hydrostatic resistance. The nanofiber membrane shows a slightly higher air permeability, but the value is insignificant with respect to the material's function. All laminates are 100% windproof.

References

1. Roey MV (1992) Water-Resistant Breathable Fabrics. *Journal of Industrial Textiles* 22(1): 20-31.
2. Ahn HW, Park Ch H, Chung SE (2011) Waterproof and breathable properties of nanoweb applied clothing. *Textile Research Journal* 81(14): 1438-1447.
3. Gorji M, Jeddi AAA, Gharehaghaji AA (2012) Fabrication and characterization of polyurethane electrospun nanofiber membranes for protective clothing applications. *125(5): 4135-4141.*
4. Růžičková J (2004) Electrospinnig nanofibers. Technical University of Liberec, Liberec, England.



Latest Trends in Textile and Fashion Designing

Assets of Publishing with us

- Global archiving of articles
- Immediate, unrestricted online access
- Rigorous Peer Review Process
- Authors Retain Copyrights
- Unique DOI for all articles